

PART NAME: KNOB SCALE: 1:1 DATE: 7/14/50 DR. BY: JWC

DAVIES MOLDING COMPANY
CAROL STREAM, ILLINOIS 60188

P/N 1475	
BASE PART	1475-05
SET SCREW	10358

THIS DRAWING IS THE PROPERTY OF DAVIES MOLDING COMPANY, IS SUBMITTED SOLELY AS A DESIGN OR ENGINEERING PROJECT. WE ACCEPT NO RESPONSIBILITY WHATSOEVER FOR THE PRACTICAL APPLICATION OF THE PIECES MADE TO THIS DESIGN.

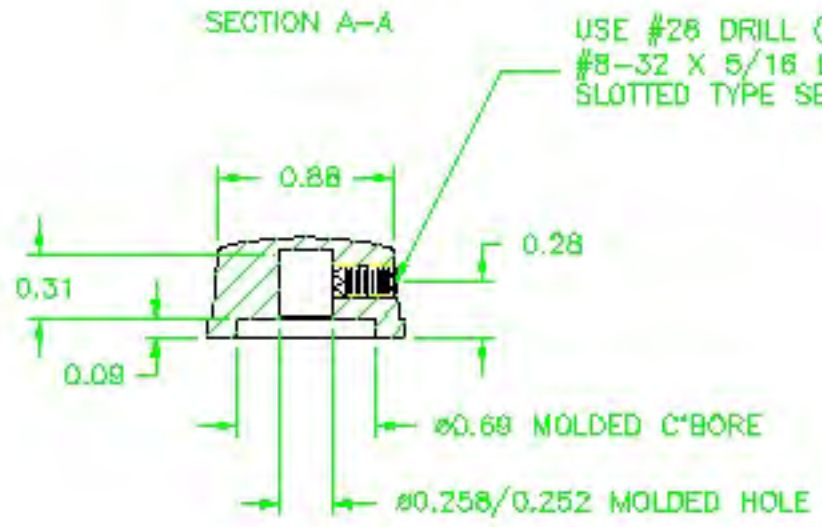
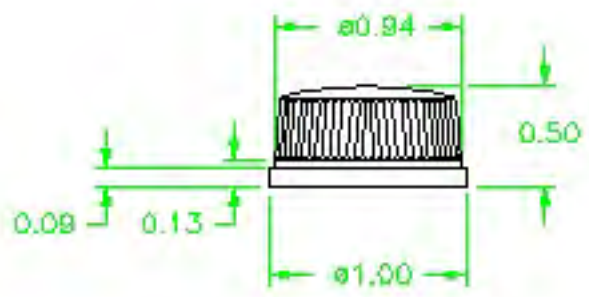
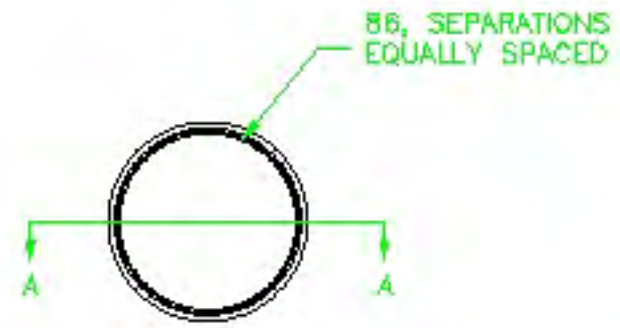

USE #28 DRILL ($\phi 0.140$), #8-32 TAP,
#8-32 X 5/16 LG. HEADLESS, CUP POINTED,
SLOTTED TYPE SET SCREW, 10358.

MATERIAL: G.P. PHENOLIC (B11)
COLOR: BLACK

TOLERANCES: UNLESS OTHERWISE SPECIFIED	DO NOT SCALE DRAWING			
DECIMALS: X.XXX ± .005 X.XX ± .015	MM: X.XX ± 0.15MM X.X ± 0.4MM	-	UPDATED/1ND TOOLBOX	ST 3/13/01
FRACTIONS ± 1/64	ANG. ± 1'	-	CAD/REDRAWN	HD 3/22/93
		A	WAS 10328	LSP 3/25/97

CHANGES